

1

2

3

4

ARGOLAS

A

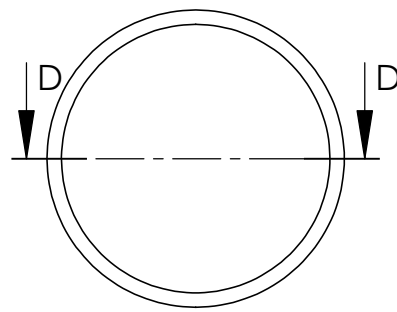
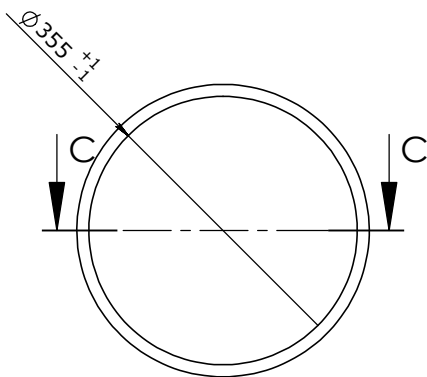

B



SEÇÃO C-C
TUBO $\varnothing 5/8''$



SEÇÃO D-D
TUBO $\varnothing 3/4''$

ENCAIXE ASSENTO

C

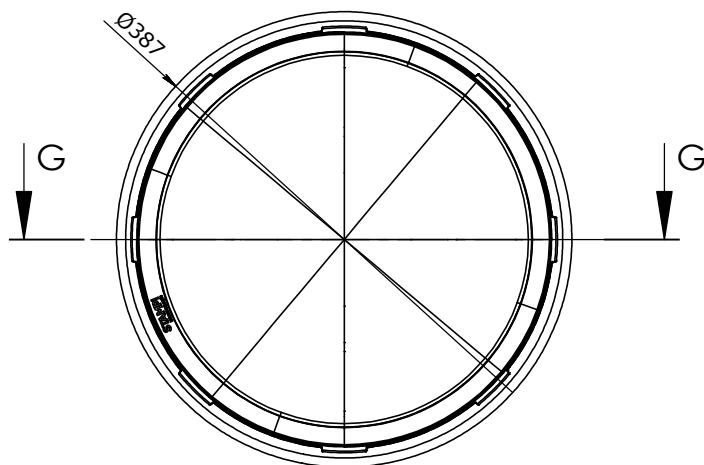

D

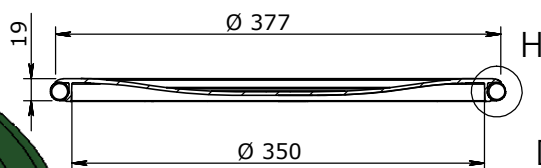
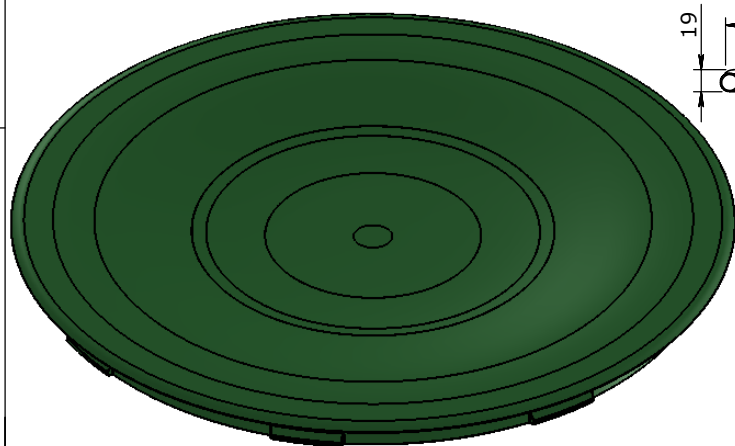

DETALHE H
ESCALA 2 : 6.5

SEÇÃO G-G
ESCALA 1 : 6.5

E

F

		TÍTULO: MT - 280 -Assento p/ cadeira liso $\varnothing 380\text{mm}$		
	DIMENSÃO DE CORTE:	CÓDIGO DO MOLDE:	QUANTIDADE DE PEÇA:	DESENHISTA:
TRATAMENTO TÉRMICO:	DIMENSÃO FINAL:	TOLERÂNCIAS DE FUROS:	DEMAIS TOLERÂNCIAS:	DATA DA IMPRESSÃO:
	MATERIAL: PP	CLIENTE:		Peso: 0.23